

Smart Switch Programmable Timer Set-Up Instructions

Model: SPT-001

The Smart Switch Programmable Timer is a Universal Programmable Timer. Just program the time required, connect the Input connection (*Fig. 2*); connect the Power and Relay (*Fig. 3*) and it's ready to go.

Programmable Time Options (Actuate to $\pm 0.1\%$)

Option 1 sets seconds from 1 to 240

Option 2 sets minutes from 1 to 240

Option 3 sets hours from 1 to 240

Option 4 sets days from 1 to 240

Input Trigger Mode 1: (*Input One*)

By using Input One the device is triggered by a switch push and release. When the timing cycle is running a second push will cancel the cycle (reset).

Input Trigger Mode 2: (*Input Two*)

By using Input Two the device is triggered by a switch push. In this mode Input One can be used to cancel the cycle (reset).

Input Trigger Mode 3: (*Using Input One & Two Wired Together*)

When this input is turned on the relay will activate, when the input is turned off the relay will stay activated as per the programmed time.

Programming the Device

Step 1 – Placing the unit in program mode (see *Fig. 3* for button layout). After wiring and applying power hold the set button down for 3 seconds. The led will give 5 quick flashes indicating you have entered program mode.

Step 2 – Setting up seconds, minutes, hours or days. (pause between pushes and wait for the led to flash).

Push the x1 button:

- Once for seconds (the led will flash once indicating second mode);
- Twice for minutes (the led will flash 2 times indicating minute mode);
- Three times for hours (the led will flash 3 times indicating hour mode).
- Four times for days (the led will flash 4 times indicating day mode . 1 day = 24 hours)

A fifth push will cancel and start back at **Step 2** (the led will give 4 quick flashes to indicate this).

Step 3 – Setting – once the above mode is selected push the set button again (the led will flash once to indicate this has been set).

Step 4 – Setting the time – Next push any combination of the x1 or x10 buttons to select the time required (the led will flash with each push indicating a valid key push).

For example:

Time required = 50 (seconds, minutes, hours or days) you can either push the x1 button 50 times or push the x10 button 5 times

Time required = 56 (seconds, minutes, hours or days) push the x10 button 5 times and the x1 button 6 times.

Step 5 – Setting – once the above time is selected push the set button (the led will flash 5 times to indicate you have now programmed the device and left program mode).

The device is now programmed and ready for use. If you make an error or want to cancel this operation simply turn the power off and back on and start again from Step 1.

Input Wiring (Fig. 2)

Mode 1 or 2

The triggering switch can be connected to Input Common and Input One **or** Input Two depending which **Mode** is required (fig 2.1) (switch not supplied)

OR from any existing switch (fig.2.2), provided it has a common negative to the Timer. (max 37v)

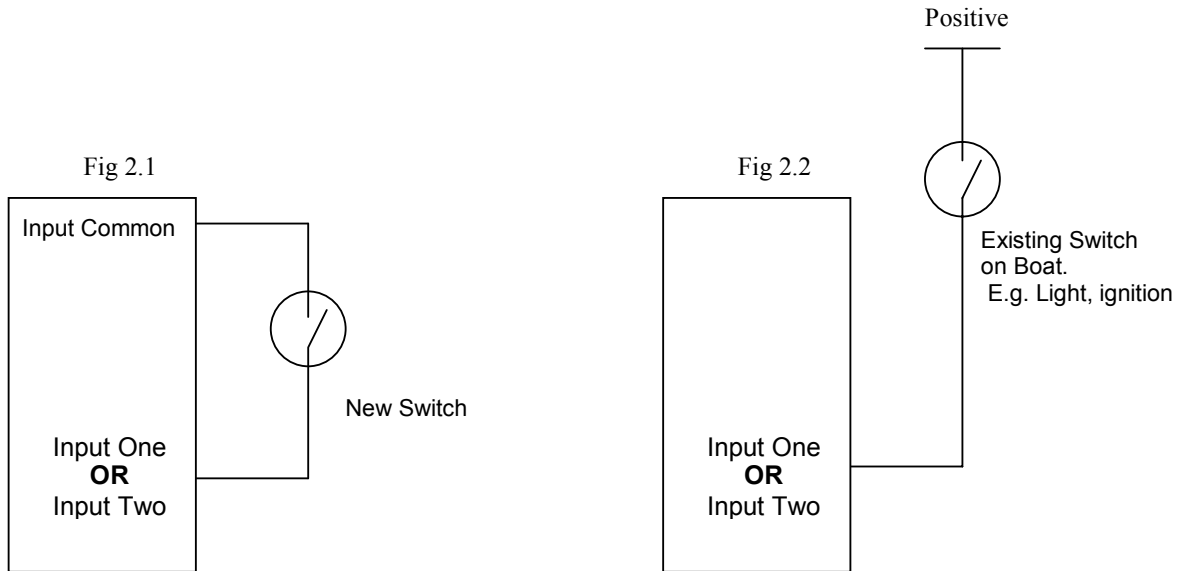

Mode 3

Loop Input One & Two together. Then connect one side of the switch to Input One and the other to Input Common (fig 2.3)

OR from any existing switch (fig.2.4) provided it has a common negative to the Timer. (max 37v)

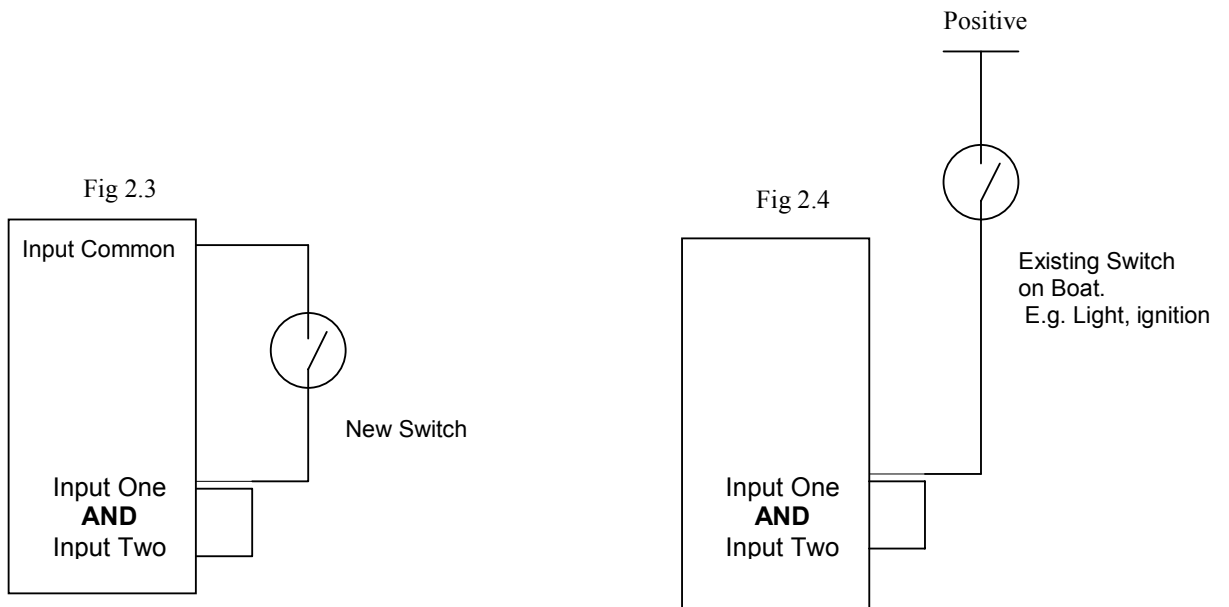

Electrical Specifications

Supply Voltage =	12 or 24 Volts DC (Auto-sensing)
Current Draw =	12 mA @ 12 Volts
Output Load =	40 amps @ 12 Volts
Input Trigger =	5 ~ 37 Volts DC
Input =	Voltage and EMI protected
Data Retention =	40 years (without power)

Output Wiring (Fig. 3)

The Relay Common Terminal is internally linked between the Positive In & Positive Out terminal. If required, this link can be removed making the Positive Out terminal the Relay Common giving clean relay contacts out. Otherwise just connect as shown below.

Fig. 3

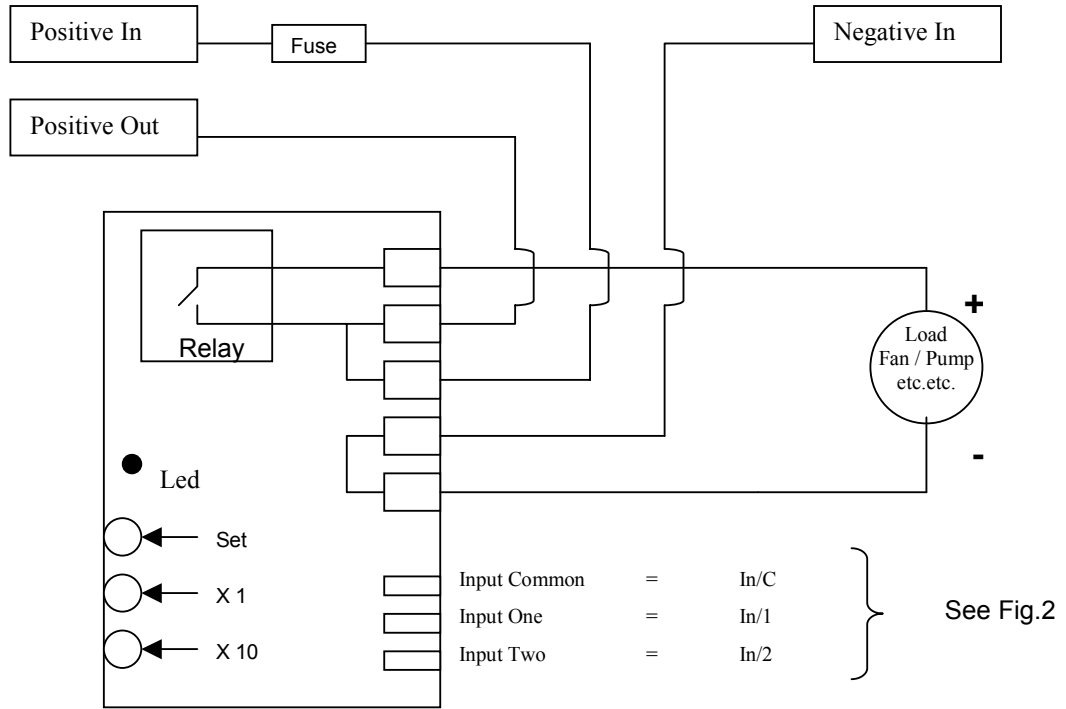

Connections

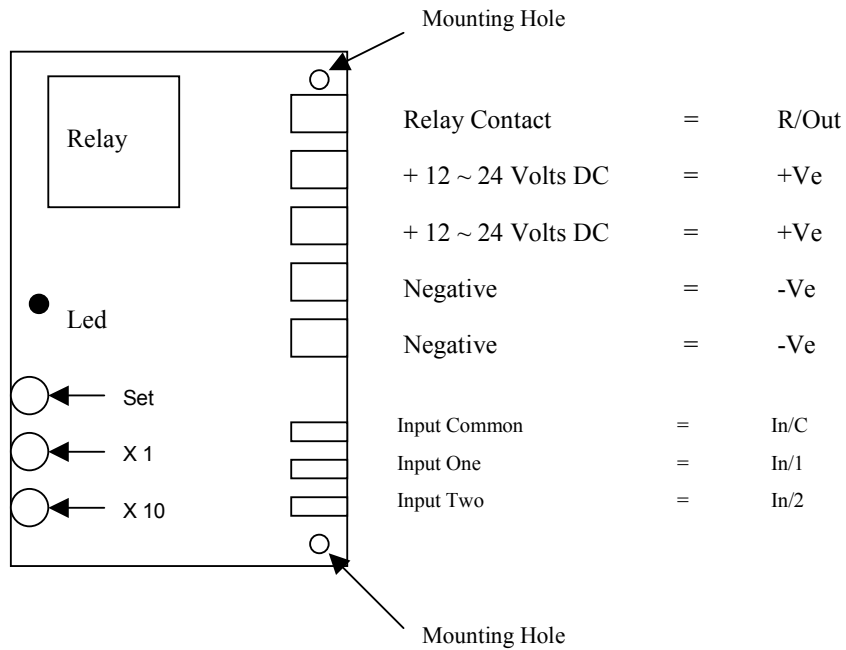

Please Note

DO NOT cover the ventilation slot at the back and top of this device.

This device should be fuse protected (*30 Amp maximum*) and mounted in a dry area.

For further inquiries visit our website at www.smartswitch.co.nz

PATENT PENDING