

AUS/SEA Holding Tank Controller Set-Up Instructions

Model: ST-660

The unique Aus/Sea Programmable Holding Tank Controller was designed as a single Holding Tank Monitoring/Control centre. The system features Manual or Automatic Control, Programmable Time Pump-out, Tank High /Low sensor inputs and an Optional Stylish Control Panel.

Optional Control Panel Part Number ST-660P

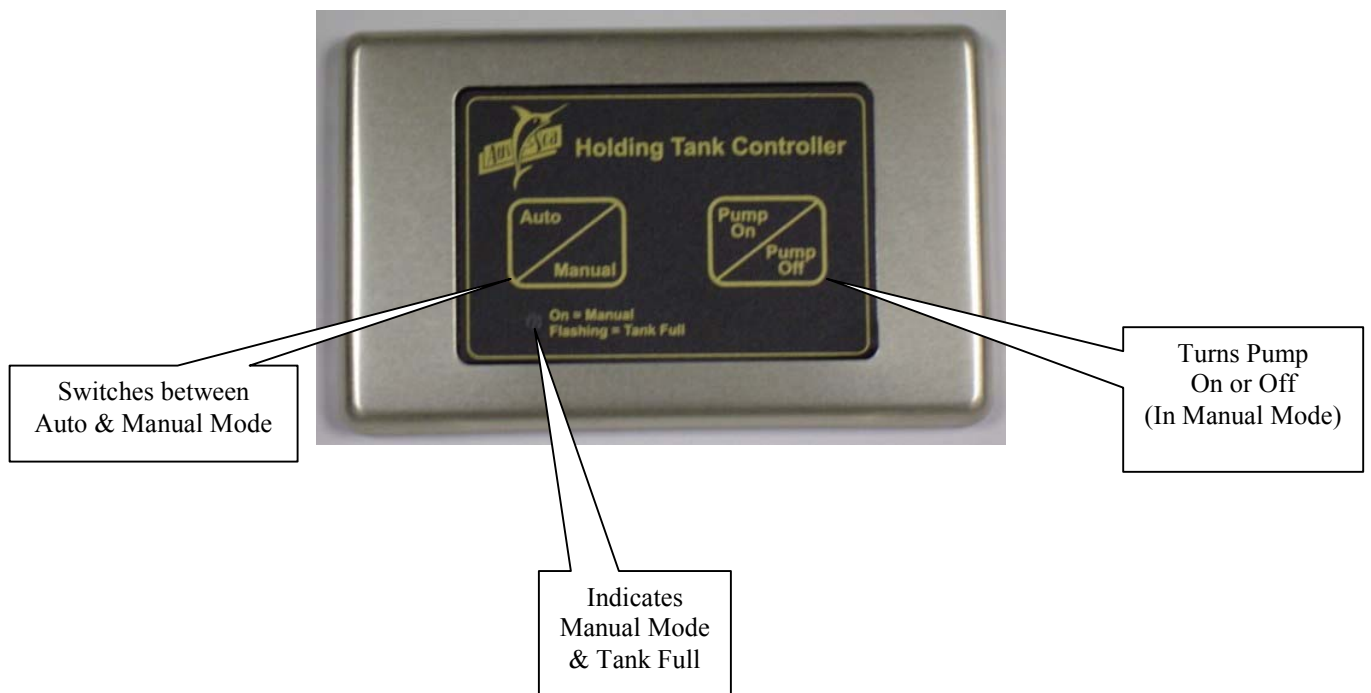

**Please Note this control panel is an optional extra.
The device will run in Automatic Mode if this is NOT installed.**

Product Overview

This device is a programmable timer designed as a single Holding Tank Controller and can be purchased with the Optional Control Panel. The unit has two inputs (Tank Low Sensor & Tank High Sensor) and two outputs. (Holding Tank Pump and an Aux output)

The unit has two modes of operation Automatic and Manual (see below for details). When power is turned on the mode is set to Automatic, there-for when the Tank High Sensor is activated the Tank Pump will startup and run automatically for the programmed time or until (if fitted) the Tank Low Sensor is activated.

NOTE: The Tank Low Sensor is optional and if NOT fitted the Pump-Out cycle will run for the programmed time. If the Tank Low Sensor is fitted the Pump-Out cycle will run for the programmed time **OR** until Low Sensor is activated.

Automatic Mode

The power on default mode is Automatic and will need to be switched to Manual mode if this mode is required. In Automatic mode the Holding Tank High Sensor will activate the Pump for the programmed time **OR** until (if fitted) the Low Sensor is activated.

Manual Mode (Requires Optional Control Panel)

The LED will indicate Manual Mode

In Manual Mode pushing the Pump On/Off button activates the Pump. Once activated the Pump will run until either 1/ the programmed time is finished **OR** (if fitted) The Low Sensor is activated **OR** The Pump On/Off button is pushed again.

Optional Control Panel

This stylish control panel can be purchased in either a Black, White, Brushed Stainless or Brass finish.

LED On = Manual Mode

LED flashing = Indicates the Holding Tank is Full. This will occur in either Auto or Manual Mode.

The Auto/Manual button selects the mode.

The Pump On/Pump Off controls the holding tank pump

Tank Low Sensor

If the Holding Tank is NOT fitted with a Tank Low Sensor Switch then a loop wire needs to be installed from Common to Tank Low Sensor Input to disable this feature. See Fig 3.

Aux Output

This Output will follow the Holding Tank full sensor. This could be used (for example) to switch on a Toilet Disable Relay.

Electrical Specifications

Supply Voltage	=	12, 24 or 32 Volts DC (Auto-sensing)
Quiescent Current	=	.045 Amps
Input	=	EMI protection
Data Retention	=	40 years (without power)
Motor Output	=	80 Amps
Aux Output	=	20 Amps

Protection = Reverse Polarity, Over Voltage, Over Temperature, Short Circuit.

Programming

Programming the Device (Also see page 4 for programming example)

Before programming PLEASE ensure the device is in Auto Mode and the Tank High Sensor is NOT activated or simply program before connecting any inputs.

Step 1 – Placing the unit in program mode (see *Fig. 3* for button layout). After wiring and applying power hold the Enter button down for 5 seconds. The led will give 5 slow flashes indicating you have entered program mode.

Step 2 – Setting up seconds, minutes or hours. (Pause between pushes and wait for the led to flash).

Push the X1 button:

- Once for seconds (the led will flash once indicating second mode);
- Twice for minutes (the led will flash twice indicating minute mode);
- Three times for hours (the led will flash 3 times indicating hour mode).

A fourth push will cancel and start back at *Step 2* (the led will give 3 quick flashes to indicate this).

Step 3 – Setting – once the above mode is selected push the Enter button again (the led will flash once to indicate this has been set).

Step 4 – Setting the time – Next push any combination of the X1 or X10 buttons to select the time required (the led will flash with each push indicating a valid key push).

For example:

Time required = 50 (could be seconds, minutes or hours) you can either push the X1 button 50 times or push the X10 button 5 times

Time required = 56 (could be seconds, minutes or hours) push the X10 button 5 times and the X1 button 6 times.

Step 5 – Setting – once the above time has been programmed, push the Enter button (the led will give 3 quick flashes to indicate this) and automatically take itself back to *Step 2*.

Step 6 –At this point you can either push the Enter button again which will program the device the led will give 5 slow flashes to indicate you have programmed the device and left program mode **OR**

Start back at *Step 2*. This allows Seconds, Minutes or Hours or any combination to be programmed.

The device is now programmed and ready for use. If you make an error or want to cancel this operation simply turn the power off and back on and start again from *Step 1*.

The device is now programmed and ready for use.

Programming Example

This example will set the Discharge Pump Time-Out for 2 minutes & 25 seconds.

Before programming PLEASE ensure the device is in Auto Mode and the Tank High Sensor is NOT activated or simply program before connecting any inputs.

Hold down the ENTER button for 5 seconds (you will see five slow flashes on the LED) this will place the unit into program mode.

NEXT

Push the X1 button **once** (you will see one quick flash on the LED) this selects seconds.

NEXT

Push the ENTER button (you will see one quick flash on the LED) the unit now knows you are about to program seconds.

NEXT

Push the X10 button **twice** and the x1 button **five** times (you will see one quick flash on the LED for each key push) this will set 25 seconds.

NEXT

Push the ENTER button (you will see three very quick flashes on the LED) this will enter 25 seconds into memory.

NEXT

Push the X1 button **once** (you will see one slow flash on the LED)
Push the X1 button **again** (you will see two slow flashes on the LED) this will select minutes.

NEXT

Push the ENTER button (you will see one quick flash on the LED) the unit now knows you are about to program minutes.

NEXT

Push the X1 button **twice** (you will see one quick flash on the LED for each key push) this will set 2 minutes.

NEXT

Push the ENTER button (you will see three very quick flashes on the LED) this will enter 2 minutes into memory.

NEXT

Push the ENTER button again (you will see five slow flashes on the LED) this will exit from program mode.

The device is now programmed and ready for use.

Wiring

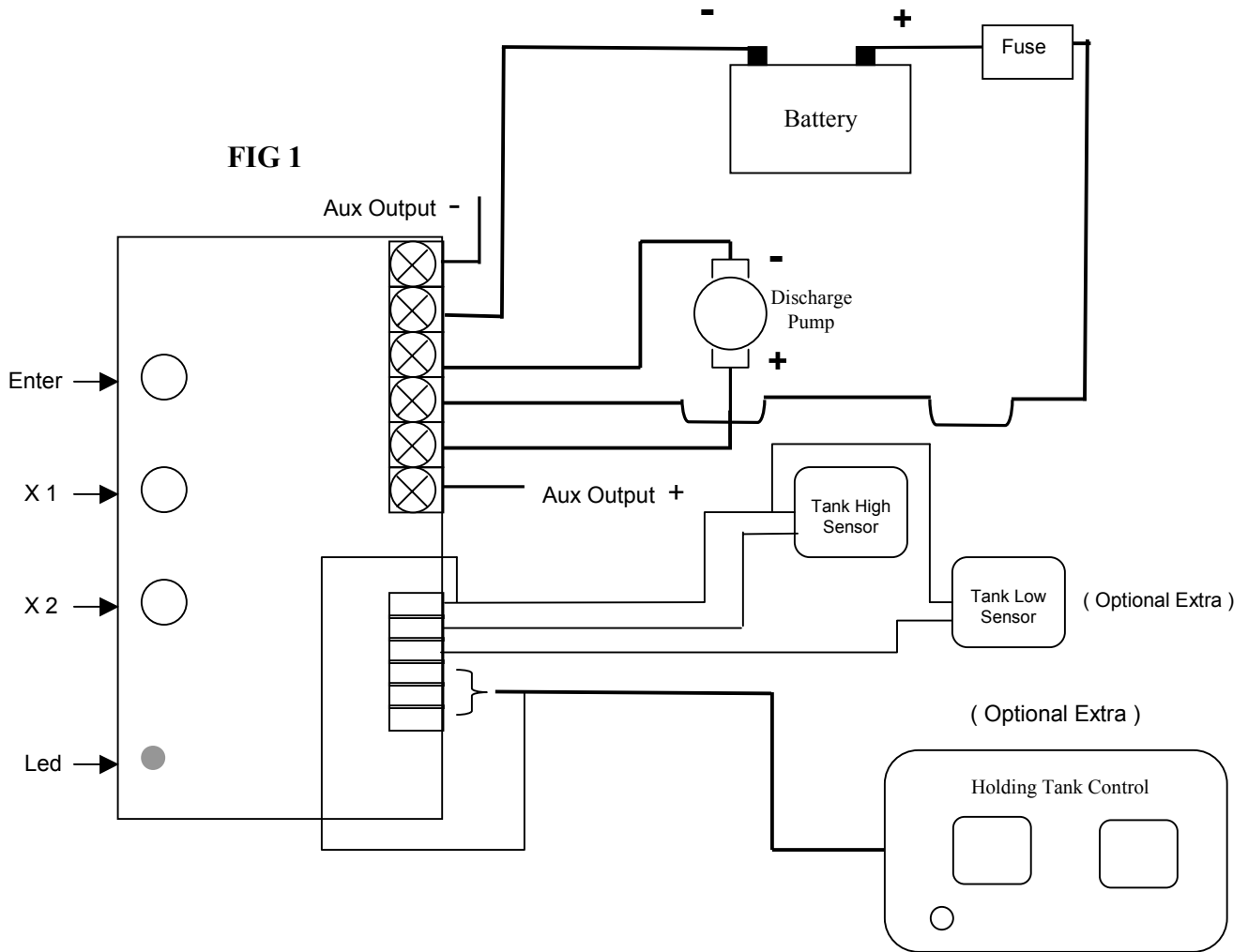

Connections Fig 3

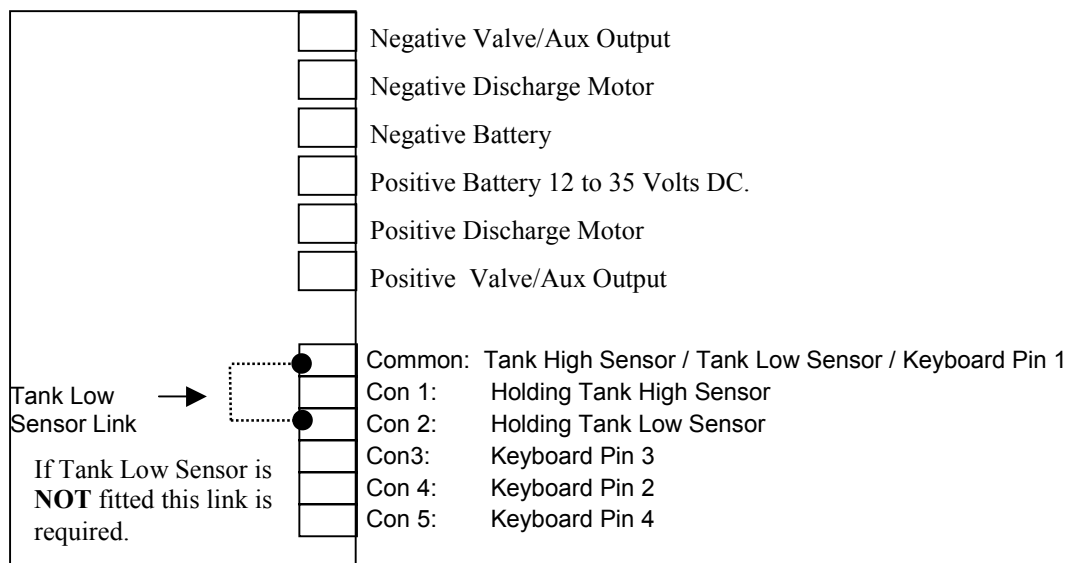

Keyboard Wiring

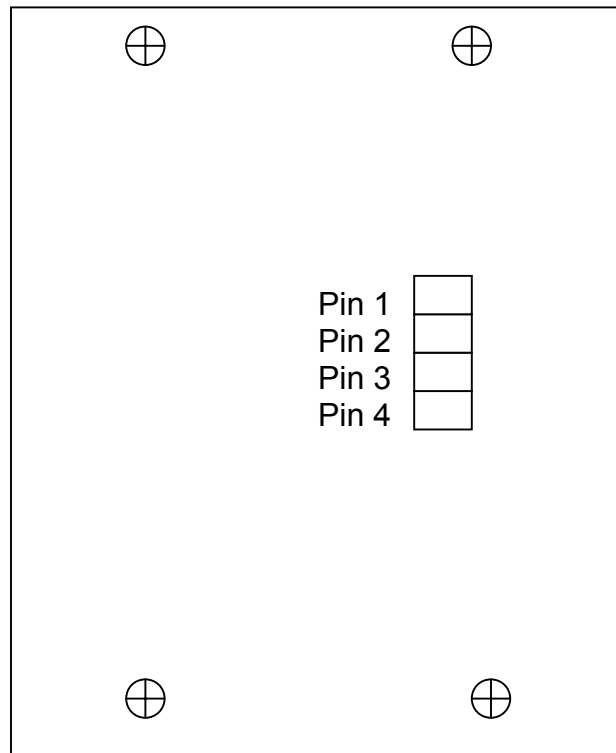

Fitting Instructions

Please Note

DO NOT cover the ventilation slot on the top of this device.
This device should be fuse protected and mounted in a dry area.

The mounting holes for the black controller are located under the top cover. Remove the four stainless steel cover screws, insert and tighten the mounting screws (do not over tighten)
Connect all cables program the device and refit top cover.

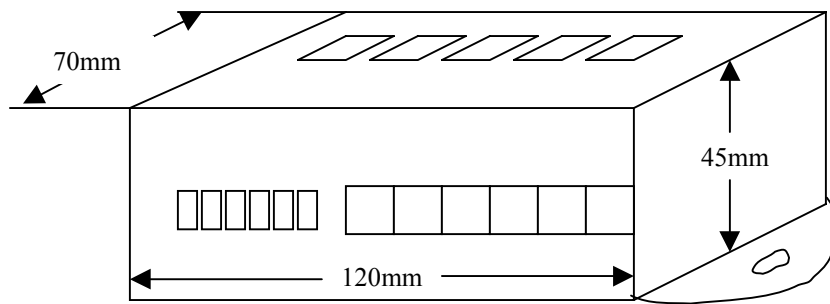

Fitting Optional Control Panel:

Drill a small hole approx 15mm through the wall for the cable, align panel-ensuring level and fasten with screws supplied. Remove the protective film from the clip on surround panel and clean with a soft cloth. Clip in place.

